

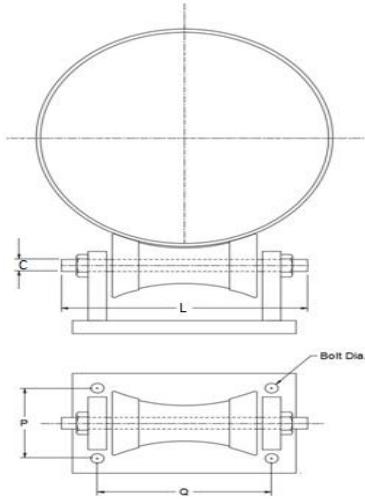

## ROLLER STAND



### FEATURES AND BENEFITS.

<b>Description:-</b>	* For support of pipe where horizontal movement due to expansion and contraction may occur.
<b>Material:-</b>	Bracket : Mild Steel Roller : MILD STEEL / CAST IRON
<b>Special:-</b>	* Electro galvanized as per ASTM B 633. * Galvanized as per ASTM A 123 / A 123M. * Designed to meet MSS Standard SP-58-2002, type 44 and SP-69.

Product Code	Nominal Pipe Size		Pipe OD (D) mm	Dimensions (mm)				Max Load (N)
	In.	mm		P	Q	CXL	Bolt Dia	
VTEPRS060	2"	DN50	60.3	100	40	M12 X 80	16	5500
VTEPRS073	2 ½"	DN65	73	100	48	M12 X 90	16	5500
VTEPRS090	3"	DN80	88.9	100	55	M12 X 95	16	5500
VTEPRS101	3 ½"	DN90	101.6	100	61	M12 X 100	16	5500
VTEPRS114	4"	DN100	114.3	115	72	M12 X 115	16	13000
VTEPRS141	5"	DN125	141.3	115	85	M12 X 130	16	13000
VTEPRS168	6"	DN150	168.3	125	100	M20 X160	16	13000
VTEPRS219	8"	DN200	219.1	130	125	M24 X 190	20	17500
VTEPRS273	10"	DN250	273	130	155	M24 X 225	20	17500
VTEPRS323	12"	DN300	323.8	130	180	M24 X 260	20	35000
VTEPRS356	14"	DN350	355.6	130	197	M24 X 275	20	35000
VTEPRS406	16"	DN400	406.4	165	220	M24 X 300	24	52500
VTEPRS457	18"	DN450	457.2	165	250	M33 X 345	24	52500
VTEPRS508	20"	DN500	508.2	165	275	M33 X 370	24	52500
VTEPRS610	24"	DN600	609.6	190	330	M52 X 480	24	65000
VTEPRS661	26"	DN650	661	200	355	M52 X 500	30	84500
VTEPRS712	28"	DN700	712	200	385	M52 X 530	30	84500
VTEPRS755	30"	DN750	755	200	405	M52 X 550	30	84500

- NOTE:-**
1. CUSTOMIZED DIMENSIONS AVAILABLE ON REQUEST.
  2. a. EP - MICRONS : 8μ - 15μ  
b. HDG - MICRONS : 70μ - 95μ

